

EXPLANATIONS

1. After assembling the system, connect the free pole of the battery to the system.
2. The system is designed to give 12VDC output at any case, whether there is line voltage or not.
3. Even if there is no line voltage, alarm and ding-dong perform their functions.
4. After line voltage is cut off, emergency light is on during next 12 minutes. After turning off, if one pushes the help button, it becomes on again.
5. The battery of the system can feed the emergency lamp during 3 hours.

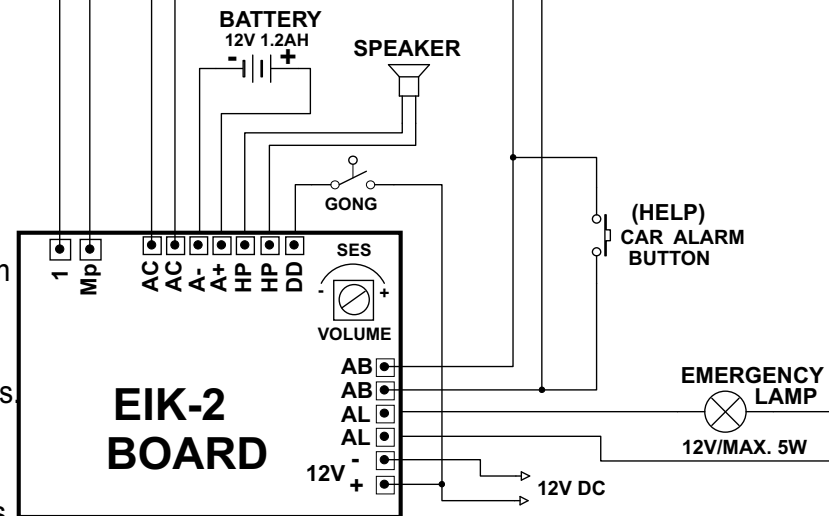

F/7.5.5.02.69

This document is a sample for applications. All information contained in these materials are subject to change by SKY ELEVATOR without notice. SKY ELEVATOR assumes no responsibility for any damage, liability, or other loss arising from these inaccuracies or errors.

SERIAL CAR CONNECTIONS				
SKY ELEVATOR	SERIES	SKY 911 (ACT)	DRW.	SKY
	PROJ.	ACT029	APPRV.	SKY
	REV.	03	DATE	12 JAN 13